

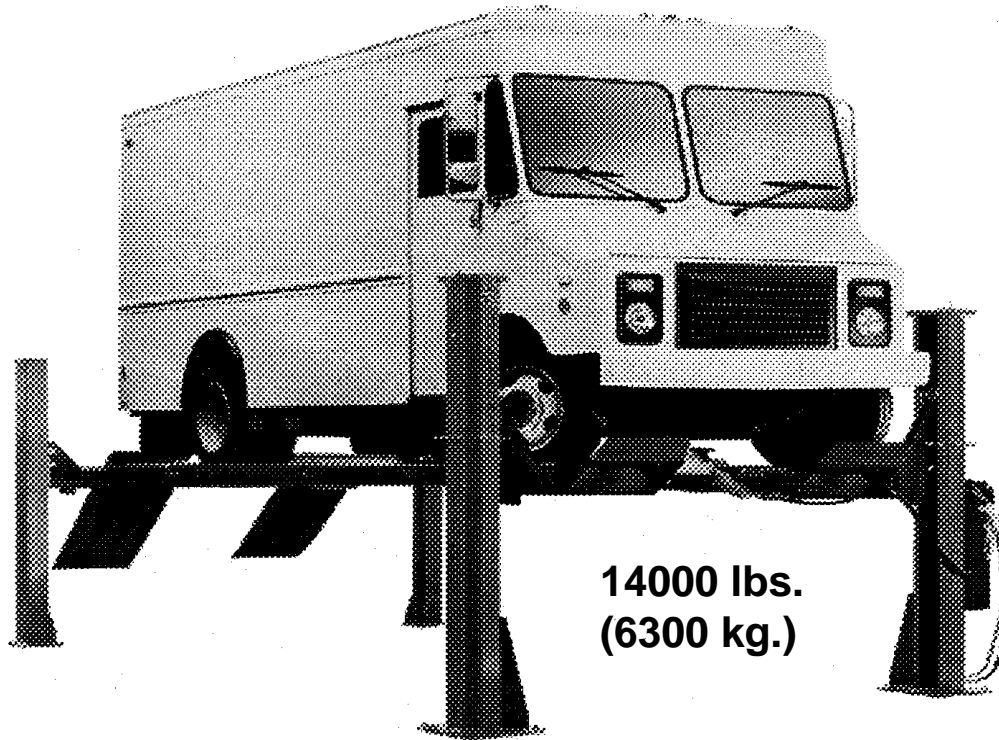

WHEELTRONIC LTD.

ORACLE

QUAD RACK
MODEL 14407



14000 lbs.
(6300 kg.)

INSTALLATION AND OPERATION MANUAL

SAVE THESE INSTRUCTIONS

**READ ALL INSTRUCTIONS
BEFORE USING LIFT**

OCT. 2004

6-1385



WHEELTRONIC LTD.

6500 MILLCREEK DRIVE, MISSISSAUGA, ONTARIO L5N 2W6
TEL: 905-826-8600 FAX: 905-826-7800

THE FOLLOWING APPLIES TO ALL LIFTS

IMPORTANT SAFETY INSTRUCTIONS

1. When using this lift, basic safety precautions should always be followed, including the following:
2. Read all instructions in this manual and on the lift.
3. Inspect lift daily. Do not operate if it malfunctions or problems have been encountered.
4. Never attempt to overload the lift. The manufacturer's rated capacity is shown on the identification label on the power side column. Do not override the operating controls or the warranty will be void.
5. Only trained and authorized personnel should operate the lift. Do not allow customers or bystanders to operate the lift or be in the lift area.
6. **Caution! Never work under the lift unless the mechanical safety locks are engaged.**
7. Always keep the lift area free of obstruction and debris. Grease and oil spills should always be cleaned up immediately.
8. Never raise vehicle with passengers inside.
9. Before lowering check area for any obstructions
10. To protect against the risk of fire, do not operate lift in the vicinity of open containers of flammable liquids.
11. Adequate ventilation should be provided when working on internal combustion engines.

SAVE THESE INSTRUCTIONS

TABLE OF CONTENTS	PAGE
1. SPECIFICATIONS	3
2. TOOLS REQUIRED	3
3. CONTENTS	4
4. INSTALLATION INSTRUCTIONS	6
4.1 Chalk Line Layout	7
4.2 Front and Rear Crossmember Identification	8
4.3 Front Cable Installation	9
4.4 Anchor Installation - Front Posts	11
4.5 Cable Installation	12
4.6 Power Pack Installation	14
4.7 Hydraulic Installation	15
4.8 Electrical Connections	16
4.9 Air Installation	16
4.10 Anchor Installation - Rear Posts	17
4.11 Leveling Procedure Safety Ladders	18
4.12 Leveling Procedure Cables	19
5. SAFETY AND OPERATING INSTRUCTIONS	20
6. MAINTENANCE INSTRUCTIONS	21
7. PARTS MANUAL	
7.1 Lift Assembly	22
7.2 Part List	23
7.3 Hydraulic and Air Kits	25
7.4 Part List Hydraulic and Air Kits	26
7.5 Cable Routing Diagram	27
7.6 Part List Cable Routing	28
7.7 Power Pack	29
7.8 Part List Power Pack	30

1. GENERAL SPECIFICATIONS

Maximum Capacity:	14000 lbs.	6350 kg
Overall Length:	266"	6756mm
Overall Width:	148"	3759mm
Down Position Height:	10"	254mm
Maximum Lifting Height:	71"	1803mm
Maximum Wheel Base:	172"	4369mm
Power Requirements:	230 Volts AC, 1Ph., 20 Amp, 60Hz.	
Shipping Weight:	4730 lbs.	2150 kg

2. TOOLS REQUIRED FOR INSTALLATION

ROTARY HAMMER DRILL
3/4" CONCRETE DRILL BIT
SOCKET FOR TIGHTENING ANCHORS
4' LEVEL
HAMMER (for anchor installation)
PRY BAR (for shim installation)
CHALK LINE (lift location)
FISH (mechanics wire to feed cable through crossmember assembly)
TAPE MEASURE
ELECTRICAL TAPE
STEP LADDER (adjusting cables and/or safety ladder in posts)
SIDE CUTTERS (for cutting shipping straps)
BAR (4' long)
4 WORK STANDS (set up)
STANDARD SOCKETS AND WRENCHES

3. CONTENTS

The 14000 lb. lift is packaged to protect from any damage that may occur in shipping. The two deck assemblies and crossmembers are packaged together with the accessory boxes strapped to them.

Main Structural Components:

- 1 - Left Side Deck Assembly (complete with hydraulic cylinder)
- 1 - Right Side Deck Assembly
- 2 - Front Crossmembers Assemblies (with air cylinder release locks and sheaves)
- 1 - Rear Crossmember Assembly (with air cylinder release locks and sheaves)

Accessory Box Components

Box 1 Contents:

- 1 - Power Post (with safety ladder)
- 3 - Post (with safety ladder)

Box 2 Contents:

- 1 - Power Pack Assembly complete with Flow Control
- 2 - Approach Ramps
- 7 - Sheave Assemblies
- 1 - Set of Cables (set contains 4 cables with nuts and spacers)
- 6 - Sheave Spacers (different sizes)
- 2 - Front Wheel Stops
- 2 - Ramp Pins
- 4 - Deck Sheave Pins
- 1 - Air Kit (with 1/4" and 3/8" polytube and fittings)
- 1 - Hydraulic Hose (with fittings)
- 1 - Hose Guard
- 4 - Sheave Covers
- 3 - Cable Tie (for attachment of hydraulic hose to cylinder)
- 2 - Recoiled Air Hoses 12' long
- 1 - Coupler 1/4" NPT
- 1 - Package of Hardware (with its own packaging list)
- 1 - Owner's manual
- 1 - ALI manual "Lifting It Right"
- 1 - Automotive Lift Safety Tips
- 1 - Automotive Lift, Operation, Inspection and Maintenance manual
- 1 - "ALI" Quick Reference Guide

GENERAL LIFT SPECIFICATIONS

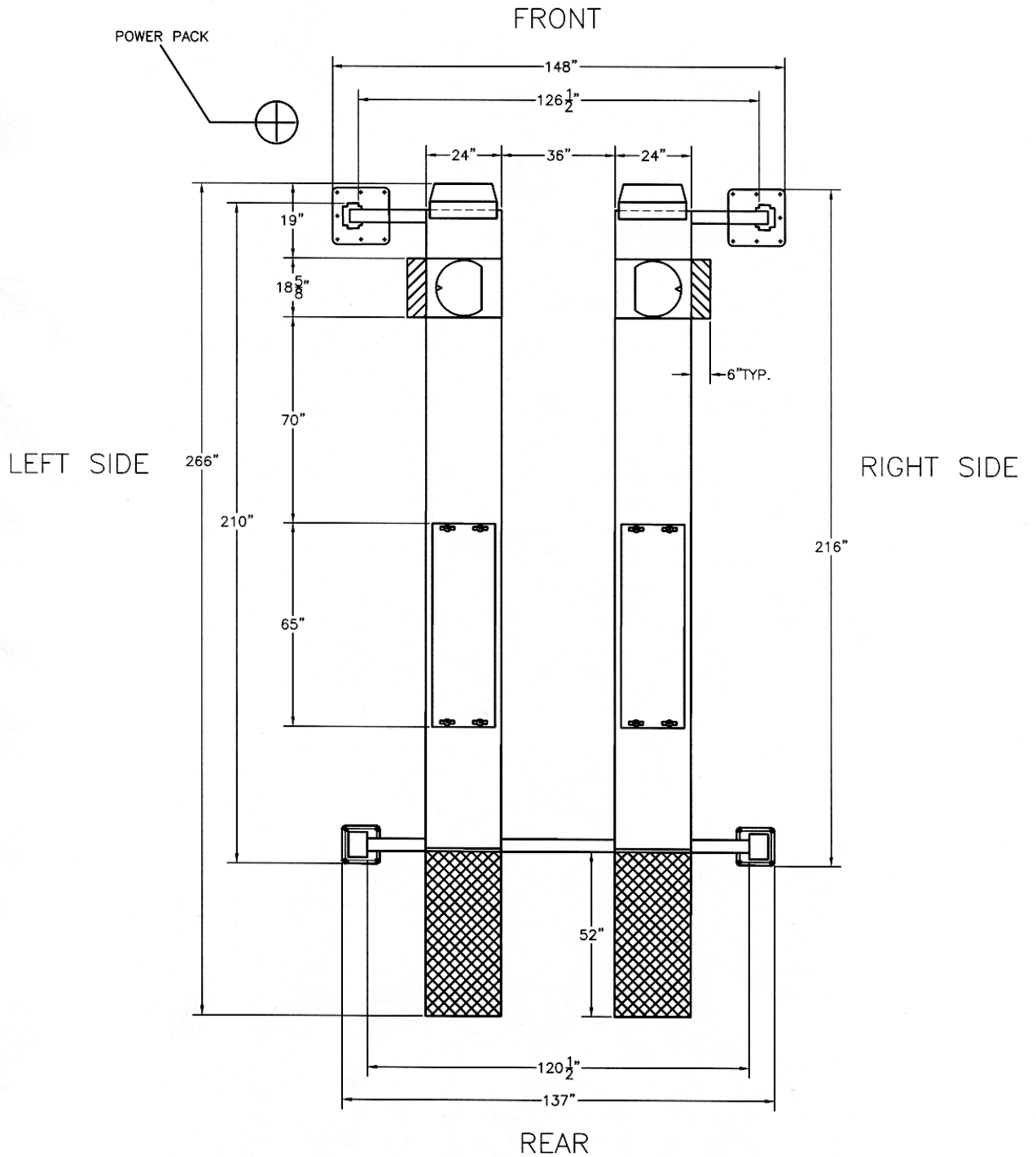

Figure 1

4. INSTALLATION INSTRUCTIONS

PLEASE TAKE THE TIME TO READ THESE INSTRUCTIONS COMPLETELY. A QUICK CHECK OF THE CONTENTS OF THE ACCESSORY BOX WOULD ALSO DECREASE THE OVERALL TIME OF THE INSTALLATION.

- Gather the tools and materials required for the installation.
- Select the location best suited for your lift.

NOTE: In determining lift area check for the following:

- Ease of driving a vehicle on and off the lift.
- Overhead obstructions, low ceiling height, overhead doors, overhead heaters etc.
- Floor obstructions, uneven floor in lift area, floor drains, work benches, electrical wiring in floor, etc.
- **IMPORTANT:** It is the user's responsibility to provide a satisfactory installation area for the lift. Lifts should only be installed on level concrete floors with a minimum thickness of five (5) inches or 130mm. Concrete must have a minimum strength of 4000 psi or 30 MPa and should be aged thirty (30) days prior to installation. Please consult the architect, contractor or engineer if doubt exists as to the strength and feasibility of the floor to enable proper lift installation and operation.
- It is the user's responsibility to provide all wiring for electrical hook-up prior to installation and to insure that the electrical installation conforms to local building codes. Where required, it is the user's responsibility to provide an electrical isolation switch located in close proximity to the lift that will enable emergency stop capability and isolate electrical power from the lift for any servicing requirements.
- An outline matching the dimensions shown in Figure 2 will need to be marked on the floor. Refer to Figure 2 for outline dimensions. Refer to General Lift Specifications for overall lift dimensions. Figure 1.

4.1 CHALK LINE LAYOUT

Figure 2

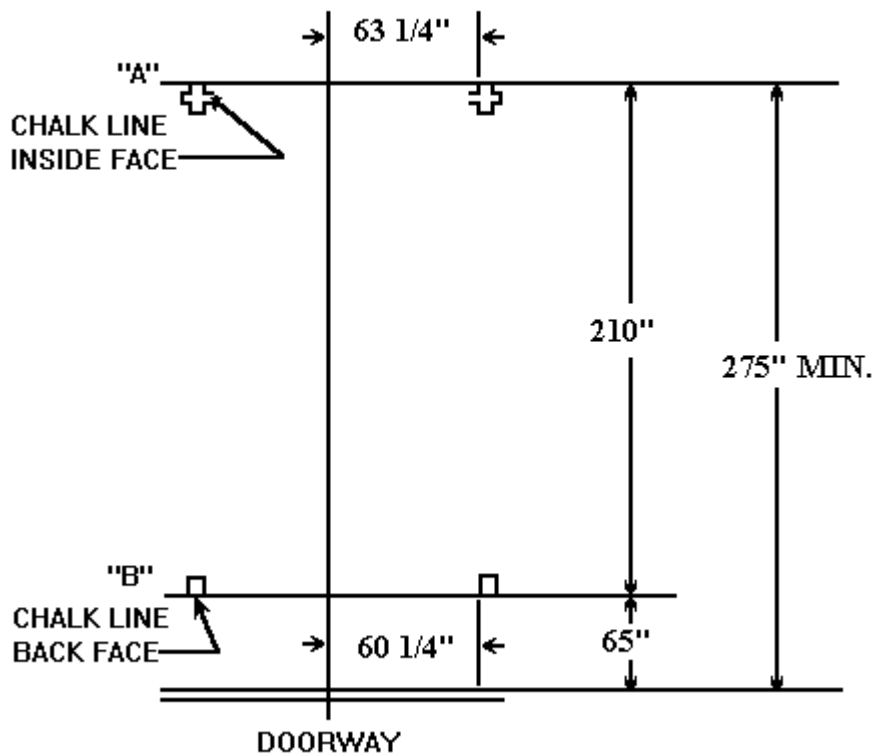

- **Refer to Figure 2.** Make a chalk line parallel to the doorway at least 275" in from the doorway. This will be the furthest front face of the front post location. Call this line "A".
- Determine the center of the doorway and bay. Make a centerline to intersect with line "A". Measure from the centerline along line "A" 63 1/4" in both directions. This will be the location of the front posts.
- Measure back from this line "A" 210". Make a chalk line parallel to line "A". Call this line "B". This will be the location for the back face of the rear posts.
- Measure from the centerline along line "B" 60 1/4" in both directions. This will be the location of the inside face and back face of the rear posts. Position work stands inside of line "A" and "B" of outline, to support the front and rear of each deck assembly.

4.2 FRONT AND REAR CROSSMEMBER ASSEMBLIES

IMPORTANT

NOTE: To determine the front, rear, left side and right side of the decks check the following:

- The left deck has the hydraulic cylinder mounted to its underside. The rear of the decks have approach ramp brackets to install the drive on approach ramps. The work steps, attached to the turn plate pocket cutouts will face towards the front outside of the lift.

NOTE: To identify front and rear crossmembers, refer to Figure 3.

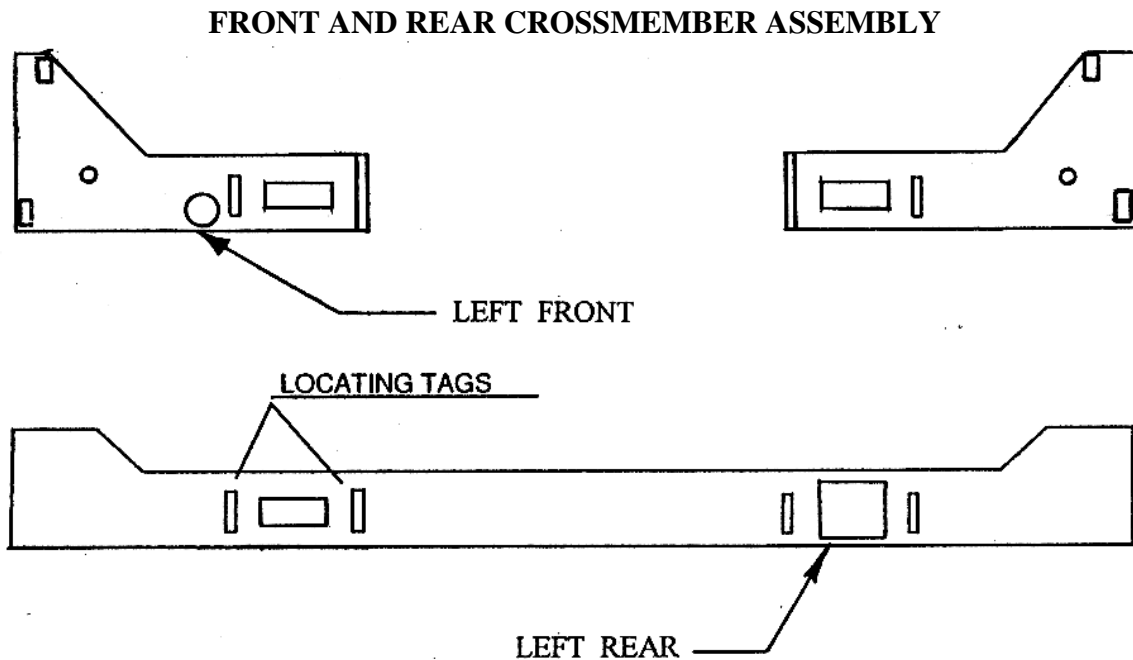

Figure 3

- The crossmember assemblies are fully assembled and the PULLEYS DO NOT NEED TO BE REMOVED FOR CABLE INSTALLATION.
- Locate the front left tower. This tower has the mounting plate for the power pack. The rear towers are identical to each other.

4.3 FRONT CABLE INSTALLATION

- Locate cables and set out on the floor. Check the part numbers located on each stud of each cable. (Refer to CABLE ROUTING DIAGRAM on p. 28)

	DESCRIPTION	PART #
Cable #1	Cable Assembly, 387" LG	2-1287
Cable #2	Cable Assembly, 178" LG	2-1094
Cable #3	Cable Assembly, 234" LG	2-1095
Cable #4	Cable Assembly, 442" LG	2-1288

NOTE: THE PULLEYS (SHEAVES) ON THE CROSSMEMBERS DO NOT HAVE TO BE REMOVED FOR CABLE INSTALLATION. A 3/8" - 16 UNC × 3" LG. HEX HEAD BOLT MUST BE REMOVED FROM THE CROSSMEMBERS TO ALLOW CABLE INSTALLATION AROUND THE PULLEYS. THIS 3/8" - 16 UNC × 3" LG. HEX HEAD BOLT MUST BE RE-INSTALLED AFTER THE CABLES ARE ROUTED THROUGH THE CROSSMEMBER ASSEMBLIES.

WARNING!!!

DO NOT APPLY LUBRICANT TO SHEAVE ASSEMBLY. FIBRE BUSHING IS PTFE SELF-LUBRICATING. THE ADDITION OF LUBRICANT WILL SHORTEN THE LIFE OF THE FIBRE BUSHING.

- At this point only the front cables will be routed for ease of installation.
- Before beginning cable routing, refer to Figure 4, Cable and Routing Diagram.
- Begin routing cable # 4 (part # 2-1288) starting at the very top of the right side of the front crossmember assembly using the non threaded end of the cable as shown in Figure 4. Place the non-threaded end of the cable at the opening of the front-right crossmember.
- Route cable # 1 (part # 2-1287) starting at the very top of the left side of the front crossmember assembly using the non-threaded end of the cable as described in Figure 4. Place the non-threaded end of the cable at the opening of the front-left crossmember.

NOTE: WHEN SLIDING FRONT CROSSMEMBERS INTO TOWERS, TILT CROSSMEMBER TOWARDS TOP OF TOWER TO PREVENT SAFETIES FROM ENGAGING.

- Remove the top plate off both the front towers, and install the front crossmembers by laying the front towers on the floor. Insert the slider blocks into the front towers through the opening on the top of the tower. Slide the crossmember down until it reaches the bottom of the tower.
- Bolt the top plate on top of the towers using five 1/2"-13UNC hex hd. bolts, nuts, flatwashers, and lockwashers.
- Stand front towers up and position as per bay layout. See Figure 1 and 2.

- Raise front crossmember to the sixth (6th) safetylock and place axle stand under beam to support it. Work stands should be placed as close as possible to the towers.
- Make sure crossmembers are inline and shim vertically.

CABLE AND ROUTING IN CROSSMEMBER ASSEMBLY TYPICAL

Figure 4

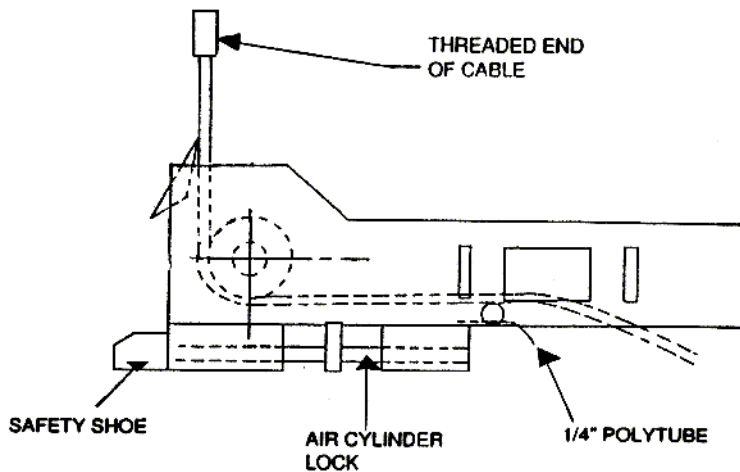

SHEAVES INSTALLATION

Figure 5

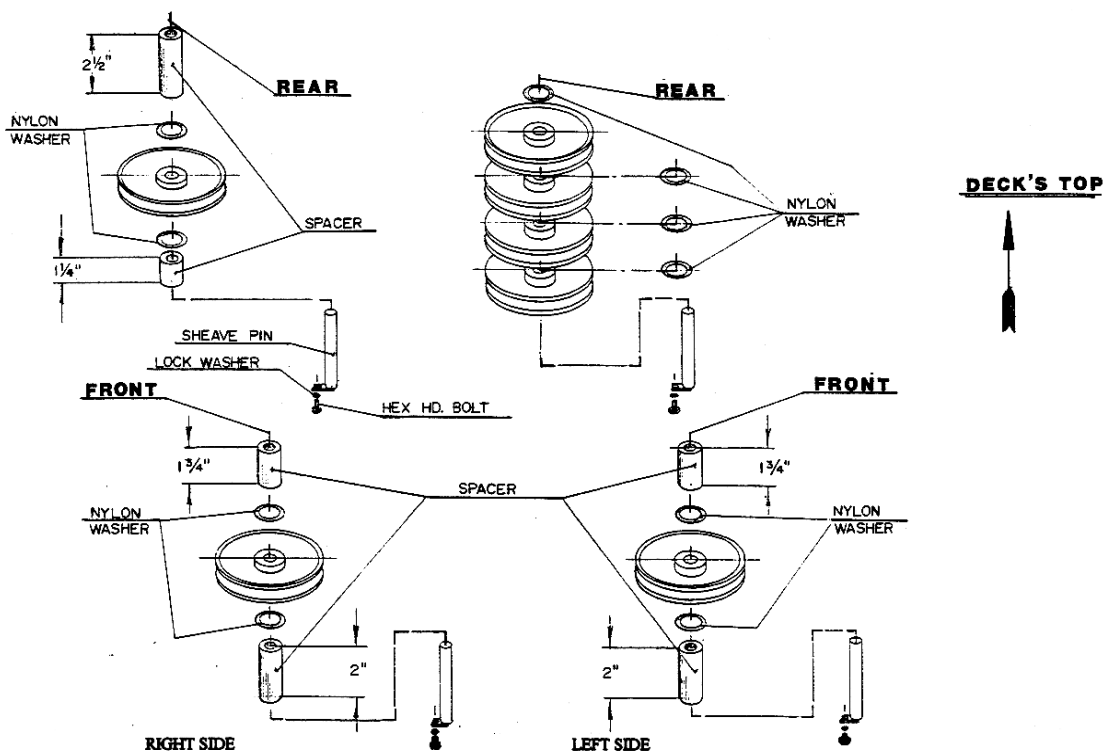

4.4 ANCHOR INSTALLATION - FRONT POSTS

- The 3/4" × 5 1/2" lg. wedge anchor bolts supplied allow for the thickness of the base plates plus a maximum of 1" of shim stock. **DO NOT USE ANCHORS SUPPLIED IF MORE THAN 1" OF SHIM STOCK IS USED.**
- Recheck all measurements before anchoring front posts.
- Using a 3/4" concrete drill bit and rotary hammer drill, drill through the concrete floor in the one (1) anchor bolt location hole positioned on rear center of the base of the front posts.

ANCHOR INSTALLATION

Figure 6

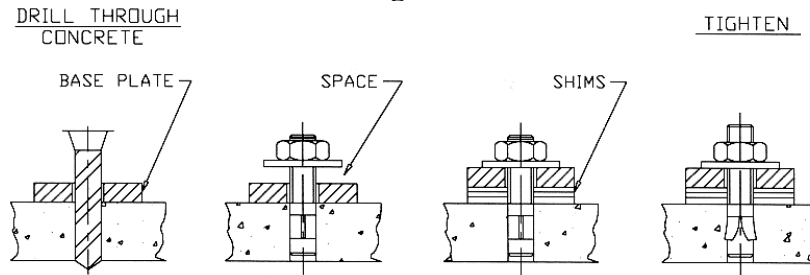

- Tighten all anchor bolts to a torque of 150 ft.·lbs.

NOTE: IN CASES WHERE THE FLOOR IS EXTREMELY OUT OF LEVEL, THE MECHANICAL SAFETIES MAY NOT ENGAGE ON THE SAME LOCK.

POST LEVELING

Figure 7

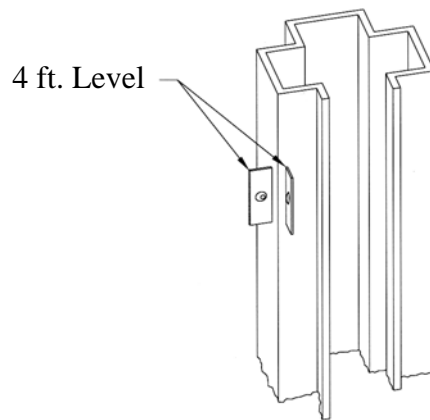

NOTE: THE 36" DIMENSION SHOWN IN FIGURE 1 IS CRITICAL. THIS WILL ALLOW JACKING BEAMS TO ROLL FREELY.

- Lower decks onto front crossmembers, and work stands located at the rear of the decks.

NOTE: CARE MUST BE TAKEN AS NOT TO PINCH ¼" POLYTUBES PRE-INSTALLED ON DECKS (FRONT & REAR)

- Locate and position the rear crossmember directly underneath the decks. Raise the crossmember to the decks and re-position work stands underneath the crossmember (The deck should fit inside the locating tabs on the crossmember).
- Install eight (8) 1/2 - 13 UNC × 1" lg. set screws to hold the decks to the front and rear crossmember assemblies. One set screw to the front and rear of each deck and one set screw into the four outer locating tabs on the front and rear crossmember assemblies.

4.5 CABLE INSTALLATION

Refer to Figure 4, 5, and Page 28

NOTE: A 3/8" - 16 UNC × 3" LG. HEX HEAD BOLT MUST BE REMOVED FROM THE CROSSMEMBERS TO ALLOW CABLE INSTALLATION AROUND THE PULLEYS. THIS 3/8" - 16 UNC × 3" LG. HEX HEAD BOLT MUST BE RE-INSTALLED AFTER THE CABLES ARE ROUTED THROUGH THE CROSSMEMBER ASSEMBLIES.

- Refer to Figure 4, Cable and Routing Diagram.
- Check for correct arrangement of spacers on sheave stacks, Figure 5.
- Install the sheave into the front of the right deck as shown in Figure 5 and Page 28.
- Continue routing the non-threaded end of cable #4 (Part # 2-1287) located at the opening on the right side of the front crossmember assembly.

NOTE: MAKE CERTAIN THAT THE CABLE RUNS BETWEEN THE WELDED GUIDE PIN AND THE GROOVE IN THE PULLEY AS SHOWN IN FIGURE 8.

**SHEAVE STACK
FIGURE 8**

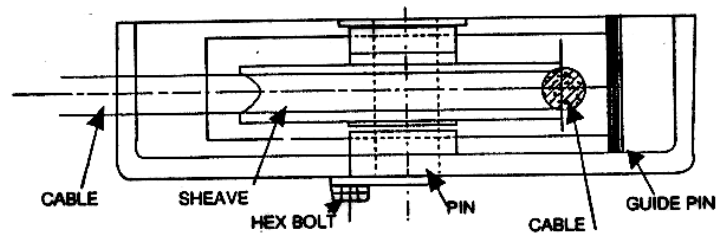

NOTE: Typical deck sheave arrangement. Left and right front deck shown; cable must run between the welded guide pin and the groove in the sheave. Left and right front spacers have equal top and bottom sizes.

NOTE: Similar arrangement for sheave stack. **Right side deck rear spacer sizes are not equal - larger goes on top of stack.**

- Continue to pull cable #4 over the center support of the right deck.
- Begin routing cable #3 (Part # 2-1095) from the right rear crossmember assembly using the non threaded end of the cable as described in Figure 4, and out through the crossmember assembly to the opening under the rear of the right deck.
- Continue to feed cables #3 and #4 through the rear crossmember assembly and out of the opening under the rear of the left deck.
- Install the sheave into the rear of the right deck as shown on Page 28, and Figure 5.
- Route cable #2 (Part # 2-1094) from the left side of the rear crossmember assembly using the non threaded end of the cable as described in Figure 4, and out through the crossmember assembly to the opening under the rear of the left deck.
- Continue routing the non-threaded end of cable #1 (Part # 2-1287) located at the opening on the left side of the front crossmember assembly.
- Install the sheave into the front of the left deck as shown on Page 28, and Figure 5.

NOTE: MAKE CERTAIN THAT ALL CABLES ARE IN THE RIGHT POSITIONS AND ARE NOT TWISTED. VERIFY THAT ALL FOUR (4) OF THE 3/8"-16 UNC × 3"LG. HEX HEAD BOLTS ARE REINSTALLED ON THE CROSSMEMBER ASSEMBLIES.

- Install the sheave stack assembly at the rear of the left deck as shown on Page 28, and Figure 5, Sheave Installation.

NOTE: ALL POSTS HAVE THE SAFETY RACKS ALREADY INSTALLED. THE LEFT FRONT POST WILL HAVE A MOUNTING BRACKET FOR THE POWER PACK INSTALLATION.

- Stand rear posts into position according to Figure 1 and 2.
- Install the threaded stud end of the cables through the top of the post. Use a 7/8" flat washer, and two (2) 7/8"-14 UNF hex nuts with cable spacers as required, to compensate for uneven floors.

NOTE: Install power pack and hydraulic hose before attempting to extend cylinder rod for cable installation.

4.6 POWER PACK INSTALLATION

- Install the power pack to the mounting bracket on the front face of the left front post using four (4) 5/16"-18UNC × 1"LG. hex head bolts and 5/16" lockwashers & flatwashers.
- Install 90° hydraulic elbow fitting on powerpack (See pg. 26, Item #10)

NOTE: WHEN WORKING WITH HYDRAULIC LINES AND VALVES, IT IS IMPORTANT TO KEEP ALL COMPONENTS CLEAN AND FREE OF DIRT.

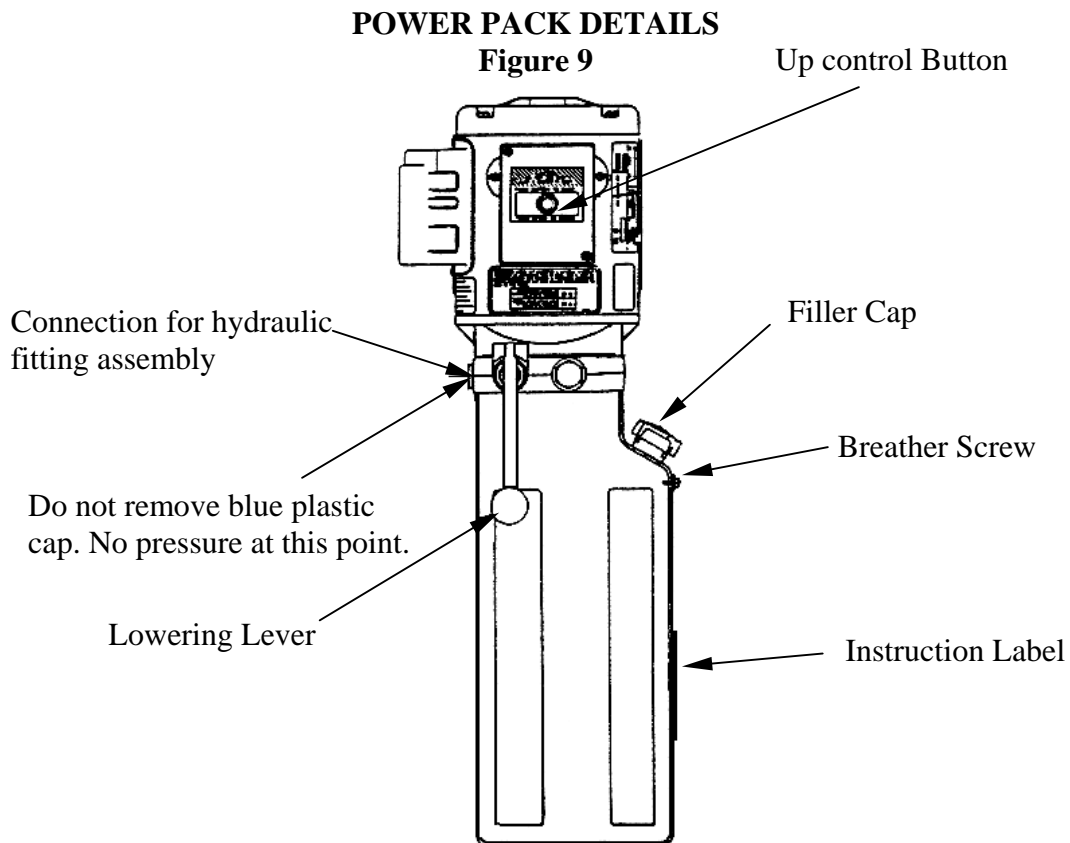

4.7 HYDRAULIC INSTALLATION

- Refer to Parts Manual, Hydraulic and Air Kit Diagram
- Locate the supply lines: 1/4" and 3/8" polytube, 3/8" flexible hydraulic line, and install the hose guard covering all three lines.
- Install the hose guard through the opening provided on the front left crossmember assembly.

TIP: TAPE ONE END OF THE HYDRAULIC HOSE TO THE TWO POLYTUBES AND FEED THEM THROUGH THE HOLE IN THE FRONT LEFT CROSSMEMBER. NOW REMOVE THE TAPE.

- Connect the 3/8" JIC-F SWIVEL end of the flexible hydraulic hose to the fitting at the cylinder. **DO NOT OVER TIGHTEN.**
- Install the flow control assembly making sure the **direction of the arrow on the flow control is facing towards the power pack. Refer to Page 26, item 17.**
- Attach the other end (3/8" JIC-F SWIVEL) of the flexible hydraulic hose to the adapter fitting on the flow control (3/8" JIC, M SWIVEL).

4.8 ELECTRICAL CONNECTIONS

CAUTION: A QUALIFIED ELECTRICIAN SHOULD MAKE ALL ELECTRICAL CONNECTIONS.

Please refer to Figure 10, Electrical Diagram for 230 volts/1 phase electrical connections.
Electrical Breaker Size Recommendation: 25Amps

Electrical Diagram for 230V/1ph.

Figure 10

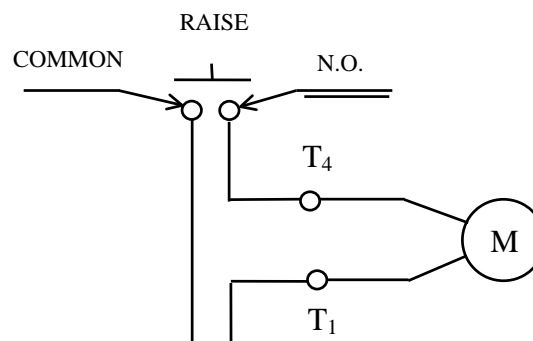

NOTE: THE CYLINDER ROD MUST BE EXTENDED IN ORDER TO INSTALL THE NON-THREADED END OF THE CABLES TO THE CABLE FLANGE ON THE ROD.

- Remove the hydraulic cap from the fitting at the base of the hydraulic cylinder.
- Depress the lowering lever, and at the same time use an air chuck to blow air into the fitting in the breather hole in the base of the cylinder to extend the rod.
- Continue to extend the rod until the non-threaded ends of the cables are reached.
- Remove the clamp from the cable flange, and install the cables.
- Reinstall the clamp to the cable flange.

4.9 AIR INSTALLATIONS

- The air valve assembly is factory installed, and is found on the outside face of the left front post protected by the mounting bracket.

NOTE: MOST OF THE 1/4" AND 3/8" POLYTUBE CONNECTIONS HAVE BEEN MADE IN THE REAR CROSSMEMBER ASSEMBLY AND BOTH DECKS - ONLY FINAL CONNECTIONS ARE REQUIRED. THE 1/4" POLYTUBE IS USED FOR THE AIR CYLINDER LOCKS AND THE 3/8" POLYTUBE IS USED FOR THE AIR OUTLETS TO THE JACKING BEAMS.

CAUTION: DO NOT OVER TIGHTEN CONNECTORS.

- Connect all of the 1/4" polytubes, coming out of the front & rear left crossmember assemblies, to the manifolds. Bolt manifolds to the front and rear of the left deck.
- Connect the opposite end of the 1/4" polytube, to the air valve on the outside face of the left front post.
- Connect the 1/4" polytubes on the front and rear right sides of the deck using two (2) 1/4" polytube adapters (Part #6-0747).
- Connect the 3/8" polytube, coming out of the front left crossmember assembly to the 3/8" polytube fitting located under the front inside of the left deck.
- Connect the opposite end of the 3/8" polytube, coming out of the front left crossmember assembly to the air valve outlet on the outside face of the left post.

NOTE: FOR THOSE UNITS EQUIPPED WITH JACKING BEAMS, THIS WOULD BE THE TIME TO INSTALL THEM. CONSULT THE JACKING BEAM INSTRUCTION MANUALS ARE FOUND IN EACH JACK BEAM BOX.

- Hook up an air supply to the inlet of the water trap on the air valve assembly located on the outside of the left post. Check for air leaks.

- Check the operation of the air cylinder locks by depressing the button attached to the air valve on the outside of the left front post.
- Fill reservoir with hydraulic fluid (ISO 32) at this time.
- Attach the hydraulic line to the inside of the left deck using the two 3/4" hose clamps and self threading screws found in the accessory box.
- Press the "UP" button on the hydraulic power pack. Continue raising the lift until it is supported fully by the cables.

NOTE: MAKE CERTAIN THAT THE MECHANICAL SAFETY LOCKS AND CABLE ROLLERS ARE WORKING PROPERLY.

4.10 ANCHOR INSTALLATION - REAR POSTS

- Recheck all measurements before anchoring rear posts. Refer to note at bottom of page.
- Using a 3/4" concrete drill bit and rotary hammer drill, drill through the concrete floor in the four (4) anchor bolt location holes positioned on the base of each post.
- Finish anchoring front posts.
- Use a 4' level, to level the posts vertically (shim if necessary). Refer to Figure 11.
- Tighten all anchor bolts to a torque of 150 ft. lbs.

POST LEVELING

Figure 11

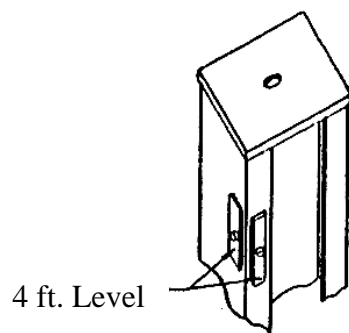

NOTE: MAKE CERTAIN THAT THE SAFETY RACK IN EACH OF THE POSTS IS SQUARE TO THE CROSSMEMBER ASSEMBLY AND THAT A CLEARANCE OF 1/8" IS MAINTAINED BETWEEN THE INSIDE FACE OF THE POSTS AND THE PLASTIC GUIDES ON THE REAR CROSSMEMBER ASSEMBLY.

4.11 LEVELING PROCEDURE - CABLES

- All cable adjustments can be made at the threaded end of the cable at the top of each of the four (4) posts.
- Tighten the two (2) 7/8" - 14 UNF hex nuts on each cable at the top of each post.
- Recheck to make certain that the safeties are engaging together.
- Raise the lift to check for full operating height of 71". This measurement is taken from the top of the decks to the floor.
- Install the approach ramps using ramp pins, cotter pins, washers, and ramps provided. Ensure the proper operation of the ramps.
- Install the front wheel stops using six (6) 1/2" - 13 UNC × 1" lg. hex bolts and six 1/2" lockwashers.
- Install the four (4) sheave covers over the sheaves in the crossmember assembly.
- Cycle the lift several times to check proper operation of the cables, safety lock, air locks, etc.

STOP IMMEDIATELY IF THE LIFT IS NOT OPERATING PROPERLY.

- Adjust and recheck for proper operation.

4.12 LEVELING PROCEDURE - SAFETY LADDERS

- Park lift on safety locks.
- Using a 4' level, adjust the safety ladders to level the lift.
- To do this loosen the 3/8" - 16 UNC \times 1" lg. hex bolts at the bottom and top back of each post and pull safety ladders up until they come into full contact with each of the safety shoes on the crossmember assemblies.
- When level, tighten the two (2) 5/8" - 11 UNC hex nuts at the top of each safety rack and the 3/8" - 16 UNC \times 1" lg. hex bolts at the bottom and top back of each post.
- Check to see if ladders engage evenly.
- If the ladders do not engage evenly, adjust cables by jogging the lift until the first safety lock engages and then tighten the other three corners until each safety lock clicks.

DECK LEVELING

Figure 12

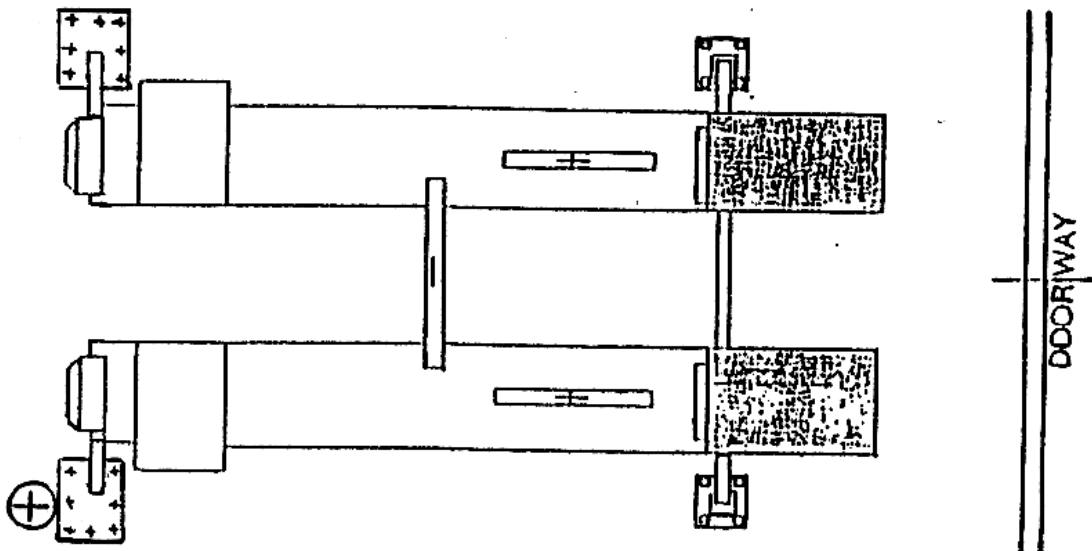

CAUTION: USE THE CORRECT WEDGE ANCHOR BOLTS. (SUPPLIED)

NOTE: Check and adjust the decks for level using the 4' level. Both the front plate cut-outs and rear steer plates should be checked.

5. SAFETY AND OPERATING INSTRUCTIONS

1. **Inspect** your lift daily. Do not operate it if malfunctions occur or damaged parts have been found.
2. **Never** attempt to **overload** the lift. The manufacturer's rated capacity is shown on the serial number tag on the power post.
3. Operating controls, **DO NOT OVERRIDE** the safeties. The mechanical safeties are designed to engage automatically on the way up. Press the up button on the power pack to go up. When the desired height is reached, release the power pack up button and lower onto the safety. To lower, raise off of the safety locks, then press the air release valve button and the lowering release lever at the same time.
4. **Only trained** and authorized personnel should operate the lift. Do not allow customers or bystanders to operate the lift or be in the lift area.
5. **Caution**, never work under the lift unless the mechanical safety locks are engaged.
6. **Before driving** vehicle on, make sure lift is in the fully down position.
7. **Before removing** the vehicle from the lift, make sure the lift is in the fully down position and ensure that all tools have been removed from the deck surfaces.
8. **Always keep** the lift area free from debris. Grease and oil spills should always be cleaned up immediately. **Never leave** any tools or parts laying on the decks.
9. **Never operate** lift with passengers in vehicle.

NOTE: DO NOT ATTEMPT TO OPERATE THIS LIFT IF ANY PART IS NOT WORKING PROPERLY OR YOU HAVE NOT READ THE COMPLETE OPERATING INSTRUCTION MANUAL.

6. RECOMMENDED MAINTENANCE GUIDELINES

Safety Instructions

- Read operating and safety manuals before using any lift
- Do not operate a lift that has been damaged or is in disrepair
- 7.1 - Proper inspection and maintenance is necessary for safe operation.
- An in-line filter/regulator/lubricator should be installed on all airlines and maintained weekly.

4-Post Lift: Daily

- Check general operation of lift.
- Check operations of mechanical safety locks.
- Check all air and hydraulic lines and fittings for pinch points, damage , cracks or leaks.
- Check all electrical wiring for pinch points, cracks or damage.
- Check operation of cables and pulleys.
- Check and drain water trapped in filter bowl.
- Check all moving parts for uneven or excessive wear.
- Repair or replace all damaged, defective, worn or broken components Immediately.
- Clean roller jack rails

4-Post Lift: Monthly

- Check anchor bolts (if loose re-torque to 150 ft. lbs.). Replace concrete if anchors continue to loosen.
- Check all air and hydraulic hoses, fittings and cylinders for leaks.
- Check level of oil in power pack reservoir when lift is in the lowered position. Add if required.
- Check cables for fraying and adjustment. Lubricate cables with cable or penetrating oil every six months.
- Check all fasteners and tighten as required.
- Check all sheaves on crossmember assembly and under the runways for wear or play. Replace immediately. Pulley pins are held in place by 3/8" - 16UNC x 1"lg. Hex Hd. bolts. Make certain that these bolts are in position and tight.

WARNING!!!

DO NOT APPLY LUBRICANT TO SHEAVE ASSEMBLY. FIBRE BUSHING IS PTFE SELF-LUBRICATING. THE ADDITION OF LUBRICANT WILL SHORTEN THE LIFE OF THE FIBRE BUSHING.

- Check and adjust safety racks if lift is not level on safety, or if safeties do not engage properly.
- If lift is equipped with rear slip plates > dismantle, clean, touch up deck surface if required, and rotate bearing cage every four months (more frequent if necessary)
- Lubricate all safety shoes and locks every six months.
- Clean front turntable bearing cage with air.
- If lift is equipped with slide blocks, clean and re-grease slide block channels in each column every two months
- Change hydraulic oil every two years.

Quarterly Slip Plate Maintenance

- Remove top Slip Plate covers by first removing the four (4) shoulder bolts on each cover.
- Remove polyethylene-bearing cages insuring that all the delrin bearings remain in the cages. Additional delrin bearings may be purchased if required.
- Clean runway surface and touch up any paint wear with a rust resistant paint. Allow paint to dry thoroughly.
- To obtain optimum performance, the position of the slip plate bearing cage should be rotated every quarter to change the wear pattern. With the first quarter maintenance, flip the bearing cage over to the opposite side. With the second quarter maintenance, rotate the bearing cage end-to-end. With the third quarter maintenance, flip bearing cage over to the opposite side. Fourth quarter maintenance should see the bearing cage rotated back to the position it started in.
- Quarterly maintenance will optimize performance and contribute to longer slip plate life.

Rolling Air Jacks

- An in-line filter/regulator/lubricator should be installed close to the pump . Add a few drops of oil to the air intake weekly if no lubricator is used or when idle for a long period of time.
- Lubricate roller bearings and roller guide springs every two months
- Dismantle and clean lift arms every four months
- Clean and lubricate lower cam rollers and hinge points every six months
- Clean and lubricate safety mechanism every six months
- Change hydraulic oil every two years

Lubrication

- | | |
|-----------------------------------|--|
| Where grease is required | > multi-purpose lithium grease |
| Where lubricating oil is required | > multi-purpose SAE 30 lubricating oil |
| Where hydraulic oil is required | > ISO 32 10W - non detergent hydraulic oil |

7 PARTS MANUAL

7.1 LIFT ASSEMBLY

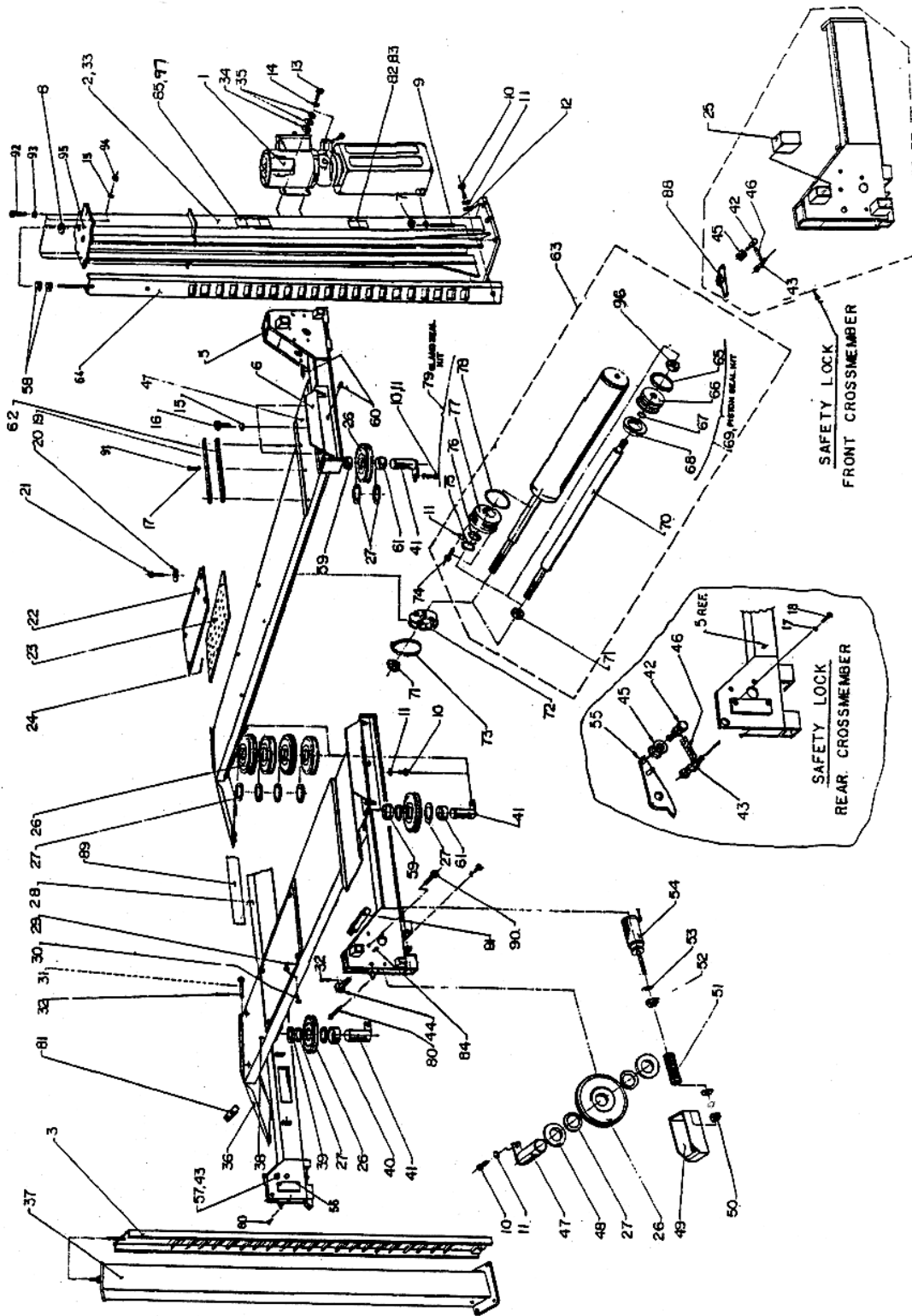

7.2 PARTS LIST

ITEM	QTY.	DESCRIPTION	PART #
1	1	POWER PACK, 230V/1PH/3HP	6-1398
	1	POWER PACK ASS'Y, 230V/3PH	6-2614
2	1	POWER POST WELDING (L.S.)	4-0429
3	2	SAFETY RACK WELDMENT (REAR)	3-0487
4	1	ALIGNMENT DECK WELDMENT (LEFT SIDE)	4-0437
5	1	FRONT CROSSMEMBER WELDMENT (LEFT SIDE)	4-0366
6	2	FRONT WHEEL STOP WELDMENT	2-0998
7	22	HEX NUT, 3/4"-10UNC	6-0737
8	26	FLAT WASHER, 3/4" I.D.	6-0738
9	22	WEDGE ANCHOR, 3/4"-10UNC X 5 1/2"LG.	6-1379
10	14	HEX HD. BOLT, 3/8"-16UNC X 1"LG. GR.8	6-0668
11	16	LOCKWASHER, 3/8" I.D.	6-0058
12	6	FLAT WASHER, 3/8" I.D.	6-0625
13	4	HEX HD. BOLT, 5/16"-18UNC X 1"LG.	6-0293
14	4	LOCKWASHER, 5/16" I.D.	6-0674
15	16	LOCKWASHER, 1/2" I.D.	6-0059
16	6	HEX HD. BOLT, 1/2"-13UNC X 1"LG.	6-0045
17	24	LOCKWASHER, 1/4" I.D.	6-0056
18	8	HEX HD. BOLT, 1/4"-20UNC X 3/4"LG.	6-0178
19	4	RETAINING BAR	2-1391
20	8	FLAT WASHER 2"O.D X 13/32I.D. X 3/32	6-0426
21	8	SHOULDER BOLT 3/8" X 5/8"LG.	6-0069
22	2	REAR SLIP PLATE (FULL FLOATING)	3-0197
23	2	BEARING CAGE	3-0196
24	1 SET	1/4" BALL BEARING	6-0829
25	8	GLIDE BEARING	2-0772
26	11	SHEAVE ASSEMBLY	2-0557
27	21	NYLON THRUST WASHER	1-0757
28	1	REAR CROSSMEMBER (WELDING)	4-0371
29	4	LOCKING PIN ASSEMBLY	2-0637
30	4	SELF TAP SCREW #10 X 1/2"LG.	6-0505
31	2	RAMP PIN WELDMENT	1-0095
32	6	COTTER PIN, 1/8" X 2" LG.	6-0115
33	1	POST WELDING (FRONT - R.S)	4-0430
34	4	HEX NUT, 5/16UNC GR.5	6-0294
35	8	FLAT WASHER, 5/16" I.D.	6-0295
36	2	APPROACH RAMP	3-0285
37	2	REAR POST WELDING	3-0347
38	1	ALIGNMENT DECK WELDMENT, (RIGHT SIDE)	4-0438
39	1	SHEAVE-SPACER 2 1/2"LG.	1-0798
40	1	SHEAVE-SPACER 1 1/4"LG.	1-0788
41	4	DECK SHEAVE PIN	2-1008
42	2	SHOULDER BOLT 3/8"DIA. X 1"LG.	6-0206
43	6	SHOULDER BOLT 3/8" DIA. X 5/8"LG.	6-0069
44	4	LOCK SAFETY PIN (WELDING)	1-1234
45	4	CABLE ROLLER	1-0766
46	8	TENSION SPRING	1-0768
47	4	CROSSMEMBER SHEAVE PIN	1-0771
48	8	SHEAVE SPACER, 3/8" LG.	1-0786

ITEM	QTY.	DESCRIPTION	PART #
49	4	SAFETY SHOE WELDMENT	2-0990
50	4	HEX. NYLON LOCKNUT, 1/4"-28UNF	6-1563
51	4	COMPRESSION SPRING	1-0767
52	4	HEX. NUT, 5/8"-18UNF	6-0662
53	4	INTERNAL TOOTH LOCKWASHER, 5/8" I.D.	6-0663
54	4	AIR CYLINDER (CLIPPARD #SRR-12-2-SP; 5 1/2" ROD EXT.)	6-0651
55	1	LOCK-SAFETY LS	2-0567
	1	LOCK-SAFETY RS	2-1475
56	4	PLASTIC BRACKET	1-0775
57	4	PLASTIC GUIDE	1-0776
58	8	HEX NUT, 5/8"-11UNC, GR.8	6-0673
59	2	SHEAVE-SPACER 1 3/4"LG.	1-0799
60	8	SET SCREW, 1/2"-13UNC X 1" LG. GR.8	6-0726
61	2	SHEAVE-SPACER 2 "LG.	1-0943
62	16	FLAT WASHER, 1/4"ID x 3/4" OD, PLATED	6-0060
63	1	HYDRAULIC CYLINDER 3.5"	4-0393
64	2	SAFETY RACK WELDMENT	3-0581
65	1	WEAR RING 3/8" WIDE X 1/8"THK. X 3 1/2"O.D.	6-0004
66	1	PISTON	2-1035
67	1	"O" RING 1 1/4"O.D. X 1" I.D. X 1/8" C/S	6-1585
68	1	PISTON SEAL 3 1/2"O.D. X 3" I.D. X 3/8"	6-0003
69	1	PISTON SEAL KIT	0-0241
70	1	PISTON ROD (MACHINED)	2-1036
71	2	HEX NUT 1 1/4"-12UNF-2A	6-1454
72	1	CABLE FLANGE	2-1037
73	1	HOSE CLAMP 4 1/2"DIA.	6-0665
74	2	HEX. BOLT 3/8"-16UNC-1 1/4"LG. GR.8	6-0666
75	1	ROD WIPER 1 1/2" X 1 7/8"	6-0001
76	1	ROD SEAL 1 1/2" I.D. X 1 7/8" O.D. X 5/16"	6-1304
77	1	GLAND	3-0522
78	1	"O" RING 3 1/2"O.D. X 1 1/8" C/S	6-0655
79	1	GLAND SEAL KIT	0-0242
80	4	HEX HD. BOLT 3/8"-16UNC X 3"LG.	6-1386
81	4	SHEAVE COVER	2-0997
82	1	SERIAL TAG	6-1306
83	1	"ALI" PLATE	6-0988
84	1	FRONT CROSSMEMBER WELDMENT (RIGHT SIDE)	4-0368
85	1	DECAL SET, ALI/WL 200	6-0988
88	1	LOCK SAFETY LS	2-0980
	1	LOCK-SAFETY RS	2-1427
89	1	"CAUTION" TAPE, (40" LG.)	6-1125
90	2	HEX HD. BOLT, 1/2"-13UNC x 3"LG.	6-1381
91	16	HEX HD. BOLT, 1/4"-20UNC x 3/4"LG.	6-0027
92	10	HEX HD. BOLT, 1/2"-13UNC x 2"LG.	6-0769
93	20	FLAT WASHER, 1/2" I.D. SAE	6-0248
94	10	HEX NUT, 1/2"-13UNC	6-0035
95	2	TOP PLATE	2-1125
96	1	LOCK NUT, 1 1/4"-12UNF	6-1453
97	1	"ATTENTION" DECAL	6-1637
98	1	KEEPER WASHER, 2"DIA. x 1/4" THK.	1-1766

7.3 HYDRAULICS AND AIR KITS ASSEMBLY

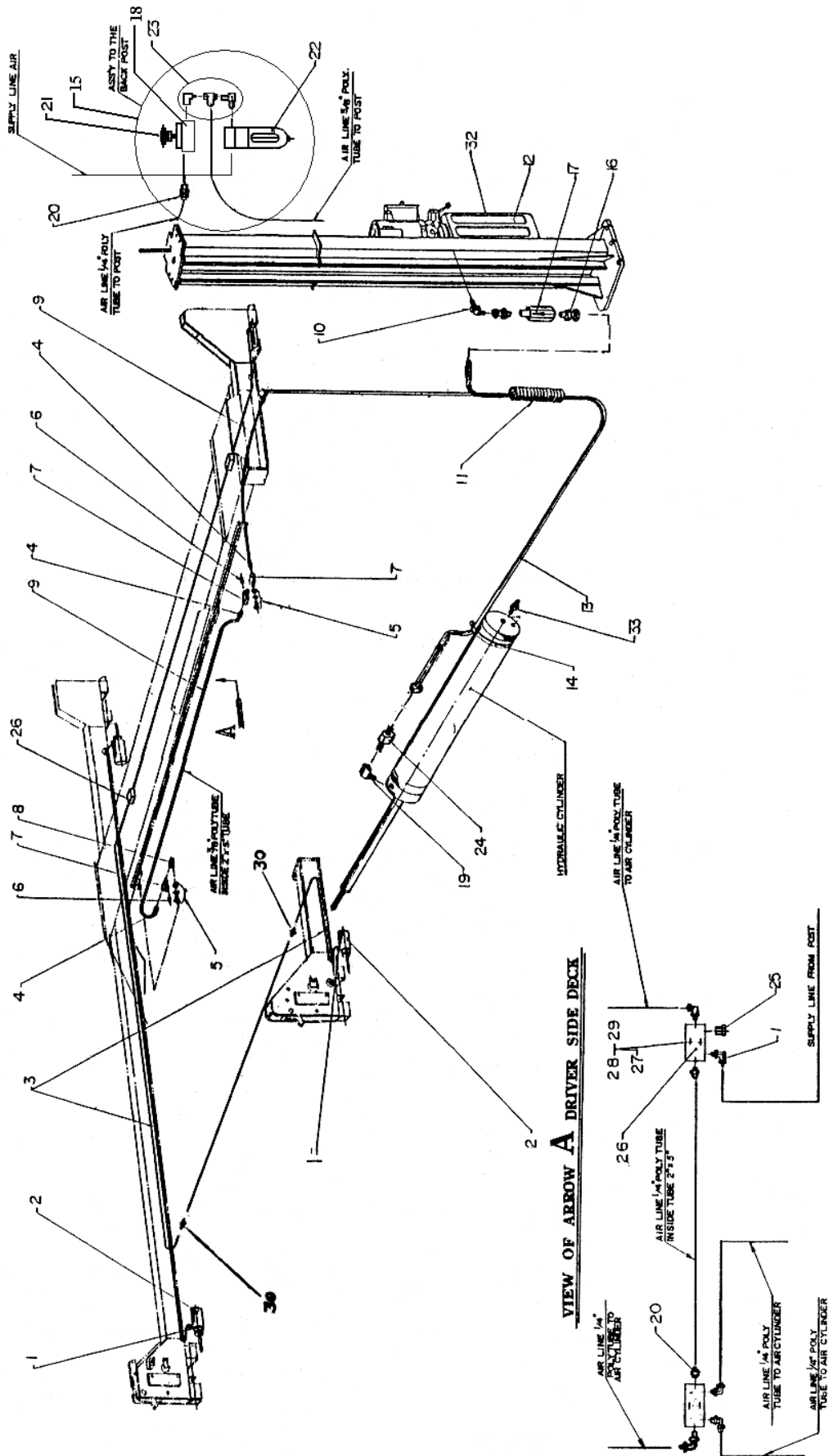

7.4 HYDRAULIC AND AIR KITS

ITEM	QTY.	DESCRIPTION	PART#
1	9	90° ELBOW, 1/8"NPT X 1/4"POLY TUBE	6-0709
2	4	AIR CYLINDER	6-0651
3	1	1/4" DIA. POLY TUBE (50' LG.)	6-0706
4	3	ADAPTER, 3/8" POLY TUBE X 1/4"NPT	6-0710
5	2	TERMINAL BOLT, 3/4"	6-0713
6	2	PLUG, 1/4"NPT	6-0282
7	3	1/4" NPT STREET TEE	6-0014
8	1	1/4" NPT STREET ELBOW	6-0015
9	1	3/8" DIA. POLY TUBE (25' LG.)	6-0707
10	1	90° ELBOW, 3/8"JIC M X 9/16"SAE M	6-0804
11	1	HOSE GUARD (4' LG.)	6-0714
12	1	POWER PACK 230V/1 PH/3 HP	6-1398
	1	POWER PACK ASS'Y, 230V/3 PH	6-2614
13	1	HYD.HOSE ASS'Y, 3/8"SWIVELx3/8"JICM, 147"LG.	6-0715
14	3	CABLE TIE	6-0731
15	1	AIR VALVE & FILTER ASS'Y	2-1394
16	2	ADAPTER, 3/8"NPT M X 3/8"JIC F, SWIVEL	6-0797
17	1	FLOW CONTROL	6-0090
18	1	3-WAY AIR VALVE	6-1775
19	1	90° ELBOW, 1/4"NPT M X 3/8"NPT F	6-0796
20	3	ADAPTER, 1/4" POLY TUBE X 1/8"NPT	6-0708
21	1	AIR VALVE PUSHBUTTON KIT	6-1777
22	1	AIR FILTER ASSEMBLY	6-0772
	1	AIR FILTER ELEMENT, (REPLACEMENT)	6-0180
23	1	AIR VALVE FITTING KIT	0-0405
24	1	VELOCITY FUSE	6-0025
25	1	PLUG, 1/8" NPT	6-0182
26	2	MANIFOLD	1-1057
27	4	HEX HD.CAP SCREW, 1/4"-20UNC X 2"LG.	6-0177
28	4	HEX NUT, 1/4"-20UNC	6-0032
29	4	LOCKWASHER, 1/4" I.D.	6-0056
30	2	1/4" POLYTUBE ADAPTER	6-0747
32	1	"LIFT OPERATION" DECAL	6-0593
33	1	ADAPTER, 1/8"NPT M X 1/4"JIC M	6-0280

7.5 CABLE ROUTING DIAGRAM

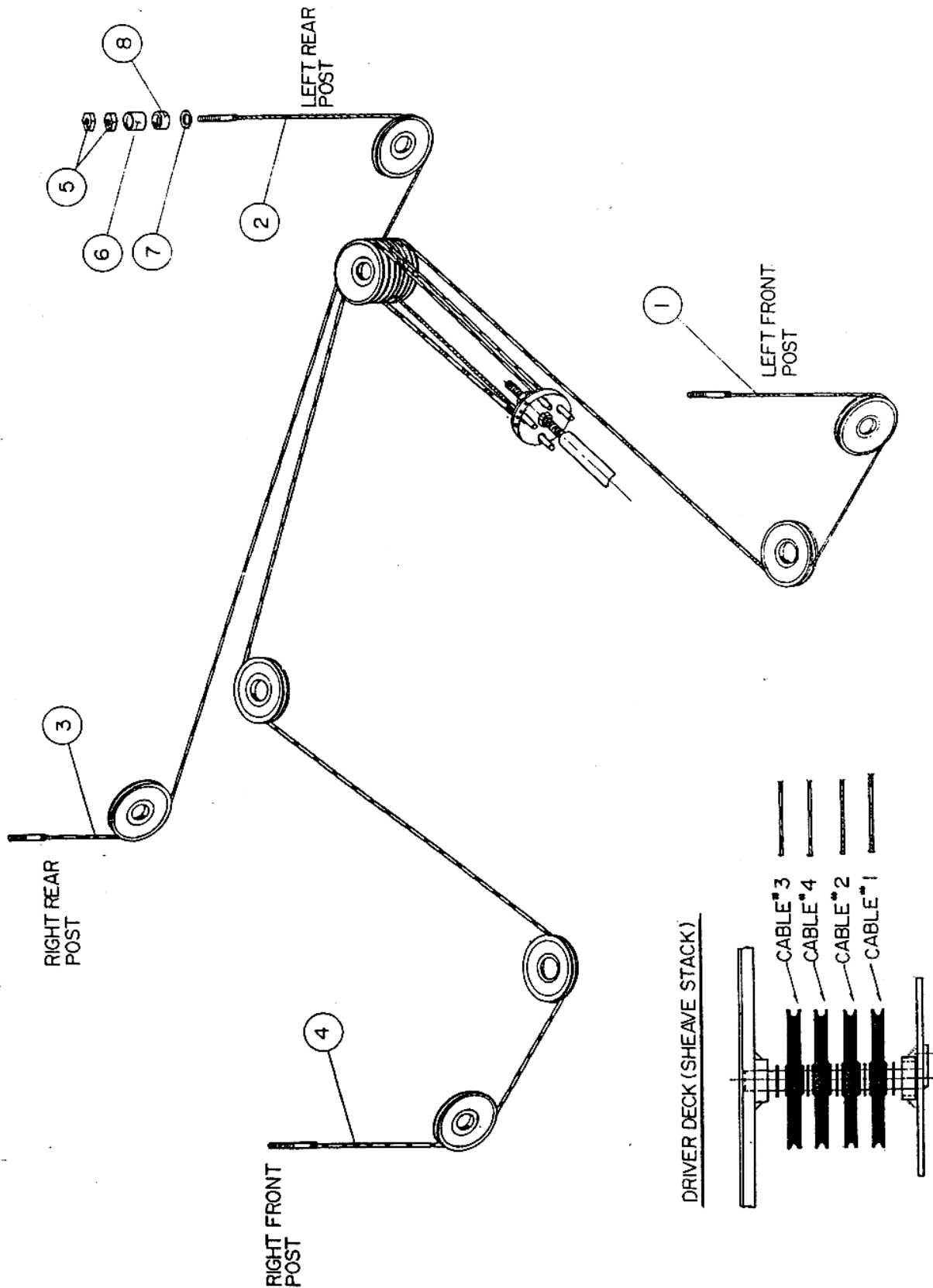

7.6 CABLE ROUTING

ITEM	QTY.	DESCRIPTION	PART#
1	1	CABLE ASSEMBLY, 387"LG. (LEFT-FRONT)	2-1287
2	1	CABLE ASSEMBLY, 178"LG. (LEFT-REAR)	2-1094
3	1	CABLE ASSEMBLY, 234"LG. (RIGHT-REAR)	2-1095
4	1	CABLE ASSEMBLY, 442"LG. (RIGHT-FRONT)	2-1288
5	8	HEX NUT, 7/8"-14UNF, GR.8	6-0724
6	4	CABLE SPACER, 2"LG.	1-0800
7	4	FLAT WASHER, 7/8" I.D.	6-0725
8	4	CABLE SPACER, 1"LG.	1-0801

7.7 POWER PACK

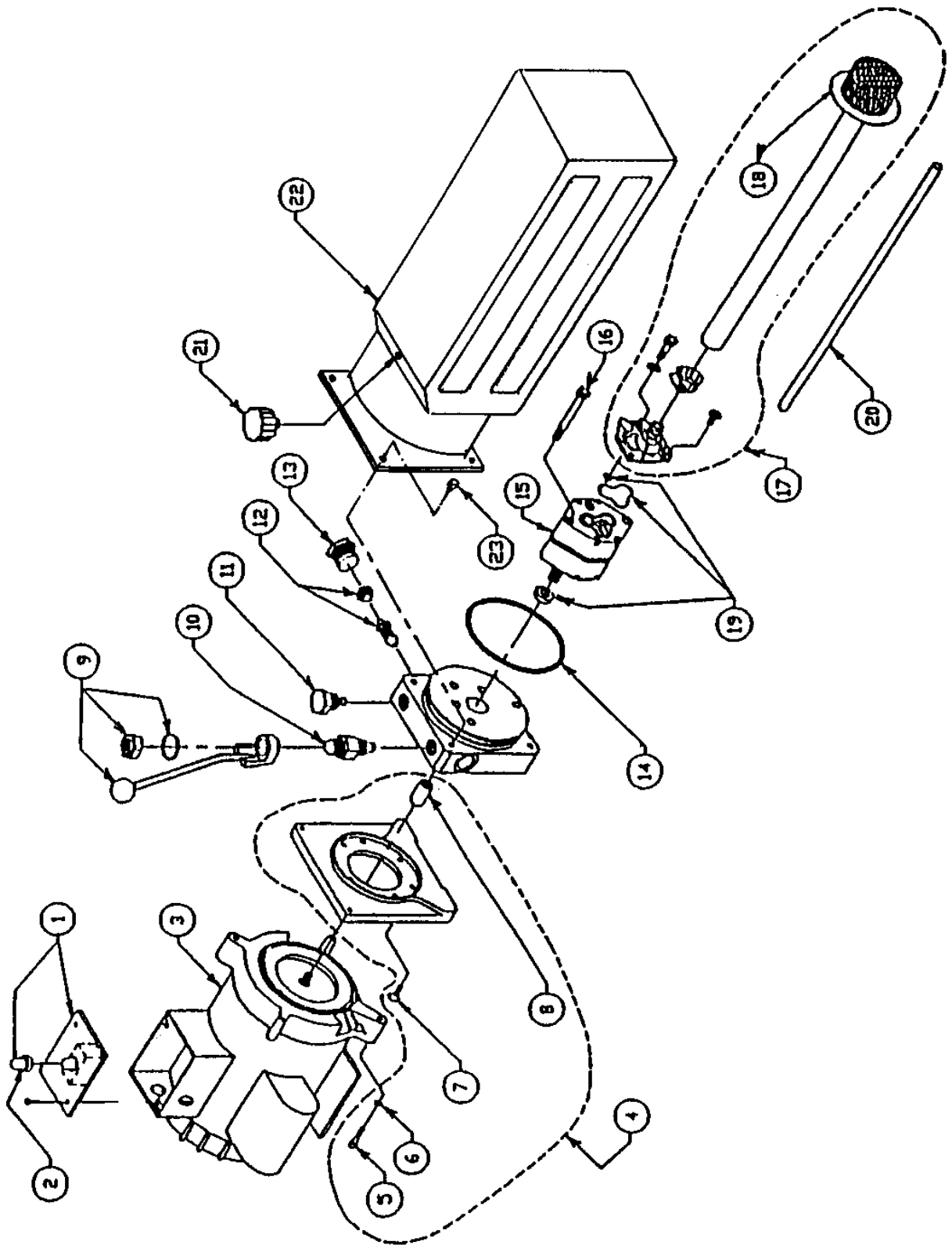

7.8 POWER PACK PARTS LIST

ITEM	QTY.	DESCRIPTION	PART#
1	1	MICROSWITCH AND WIRING ASSEMBLY	6-0881
2	1	MICROSWITCH BOOT	6-1084
3	1	MOTOR, 230V AC, 1 PHASE, 60 HERTZ, 3HP	6-1959
	1	MOTOR, 230V AC, 3 PHASE, 60 HERTZ	6-1079
4	1	MOTOR ADAPTER KIT	0-0197
5	4	SOCKET HD.CAP SCW. 1/4"-20UNC X 1 5/8"LG.	6-1085
6	4	LOCK WASHER, 1/4" I.D.	6-0056
7	4	ALLEN FLAT HD.SCW. 1/4"-20UNC X 3/4"LG.	6-1086
8	1	COUPLING	6-0774
9	1	RELEASE BRACKET & HANDLE ASSEMBLY	6-0776
10	1	VALVE CARTRIDGE RELEASE	6-0880
11	1	VALVE CARTRIDGE CHECK	6-1087
12	1	FIXED RELIEF VALVE ASSEMBLY (RV 23)	6-1323
13	1	RELIEF VALVE CAP	6-1089
14	1	RESERVOIR "O" RING	6-0875
15	1	PUMP ASSEMBLY, 2.5CC/REV	6-1958
16	2	PUMP MOUNTING BOLT	6-1090
17	1	INLET PLUMBING KIT	0-0198
18	1	INLET HOSE / FILTER ASSEMBLY	6-0786
19	1	PUMP "O" RING KIT	0-0199
20	1	RETURN TUBE	6-0783
21	1	BREATHER FILLER CAP	6-0784
22	1	RESERVOIR	6-0785
23	4	RESERVOIR SCREW	6-1091

CAUTION

ALL SAFETY LADDERS USED ON 4-POST LIFTS ARE PRELOADED.

REMOVING THE BOLT HOLDING THE BOTTOM PORTION OF THE SAFETY LADDER WITHOUT PROPER PRECAUTIONS CAN RESULT IN INJURY.

PLEASE CONTACT CUSTOMER SERVICE FOR PROPER REMOVAL INSTRUCTIONS.

